

# HAMONT

*Universal automatic biomass combustion  
warm water boilers*

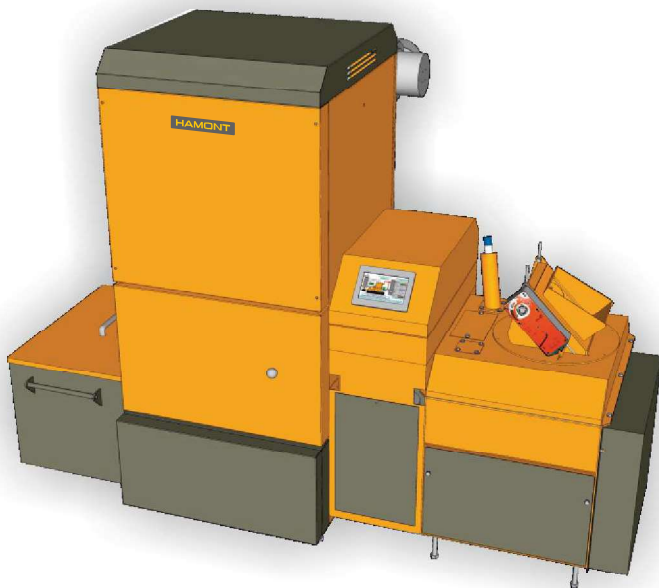

**40-101 kW**

*Joinery workshops  
Residential houses  
Pensions, hotels  
Schools, municipal buildings*

**150-500 kW**

*Industrial halls  
Furniture factories  
Housing estates  
District heating projects*

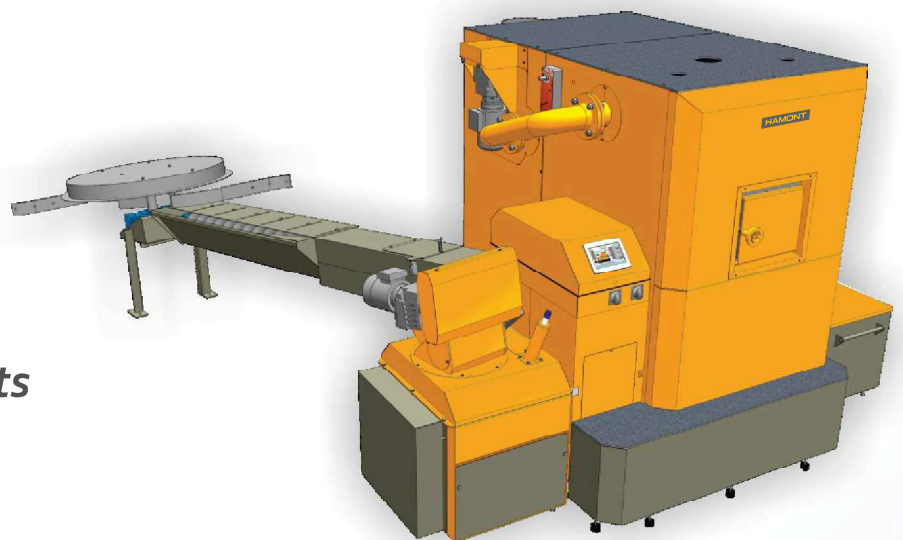

*From an environmental alternative to energy independence.*



# CSTfire future for the environment

Production of boilers on the premises of Vaněk - engineering production

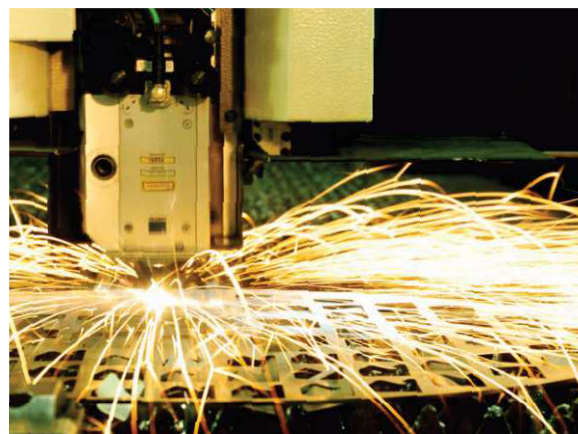

- First-class production technology
- Certified production processes
- Long-term experience in the field
- Customer-oriented approach
- Exclusively Czech capital
- Own development and construction
- Cooperation with research institutes



- Hundreds of installations in Europe and the USA
- Distribution of spare parts to customers
- Development of sales network in Europe
- Ensuring customer service
- Consulting activity

# Product Properties **HAMONT**

Biomass boilers Hamont continued in the best tradition of manufacturing automatic boilers with high degree of comfort in basic version. The boilers are produced with validate European standard ČSN EN 303-5: 2013 and they are certified by engineering test institute Brno (SZU), which is Notified body 1015, accredited for assessment of conformity. The boilers comply with **Commission Regulation (EU) No 2015/1189** on ecodesign for these fuels.

## They are mainly characterised by the following:

- Fully automated operation
- Ecological and Economic operation
- Regulated the range of 30-100%
- Protection against reverse burning
- Optimizes the combustion process by monitoring the oxygen surplus values with lambda sensor.
- Container 1 -1,4 m<sup>3</sup> type USV
- Fuel transfer from warehouse (type USZI)
- High-temperature combustion chamber with continuous monitoring of under pressure
- Combustion crown – primary and secondary fans.
- The ash is automatically conveyed to the ash container
- Automatically cleaning of heat exchanger
- Automatically ignition
- Independent grating fuel
- Exhaust fan, ceramic deflector
- Control unit with 7" colour touch screen
- Operation visualization can be connected by the Internet, distance control, subtraction of date
- Universality of fuel
- Possibility of setting individual weekly schedules of controlled peripherals (buffer tank, heating branches and DHW).
- Program can be adapted to customer requirements



# Description of the **HAMONT** 40-101 kW boiler and functions

**Power series :** 40 kW - 49 kW - 60 kW - 80 kW - 99 kW - 100 kW - 101 kW

The boilers are supplied either with a 1-1.4 m<sup>3</sup> volume fuel container (USV) or with a central staging device, which automatically feeds the fuel in from the central warehouse to the intermediate boiler container (USZI). The fuel is transported via a screw conveyor into the boiler's combustion chamber where it is ignited automatically. The boiler is equipped with a high-temperature combustion chamber with a round burner and primary air inlet, with an additional combustion crown above with a secondary air inlet.

Both connections of combustion air are controlled by two independent fans. The flow of exhaust gases is corrected prior to entering the heat exchanger, using a so-called deflector that ensures optimum finish-combustion. For the present power series, the heat exchanger is located above the hearth and the cleaning of its heat transfer surfaces

is provided automatically. In this way, the high efficiency of the equipment is ensured. The optimum flow of flue gases is provided for by an exhaust fan. Once the combustion process has been completed, the ashes are conveyed to the ash container by two screw conveyors. The function of the entire boiler is controlled by a control unit, which allows the setting of the required mode for various fuels, as well as two-way communication via a GSM modem. In the basic menu, the control unit enables visualization and remote access via the Internet on PC and mobile phone. The control unit optimises the combustion process across the entire range of the boiler's powers by continually reading the oxygen surplus in the flue gases by a lambda sensor. That ensures the high efficiency of the facility across the entire range of controllability. Boiler power can be regulated within the range of 30 to 100%.

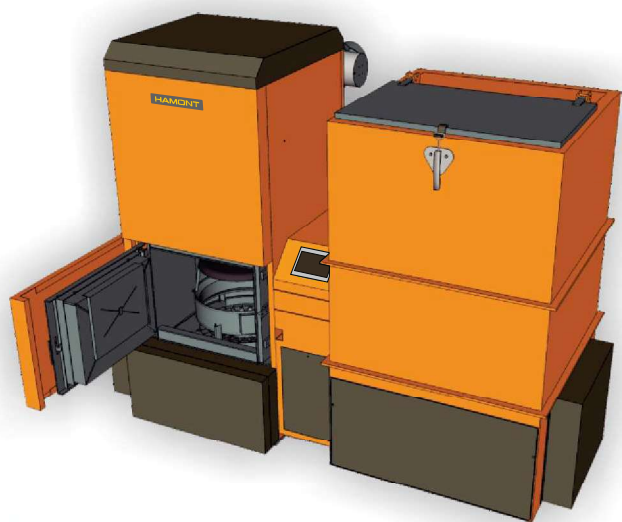

**Model USV**



**Model USZI**

## Front cross-section

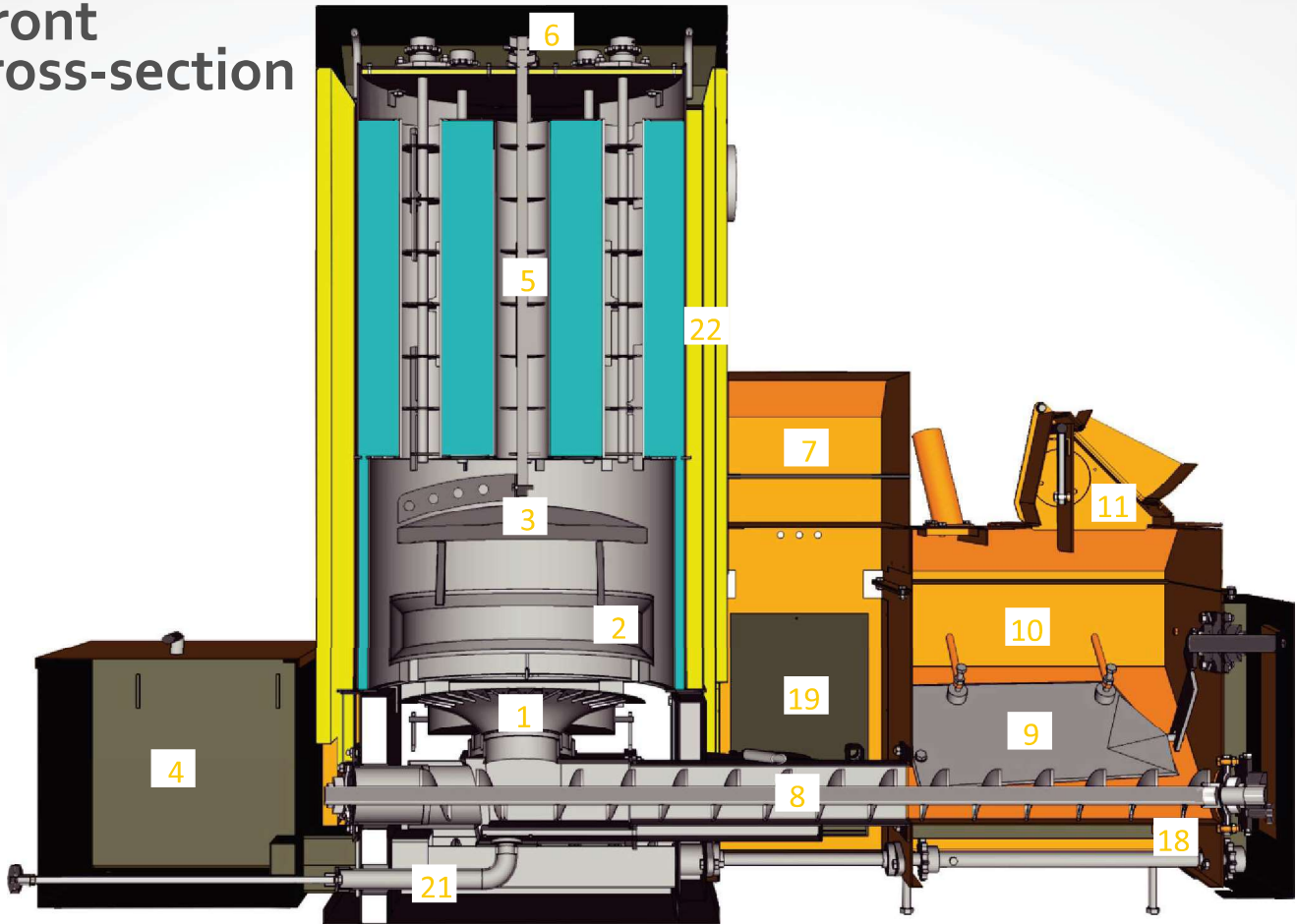

## Side cross-section

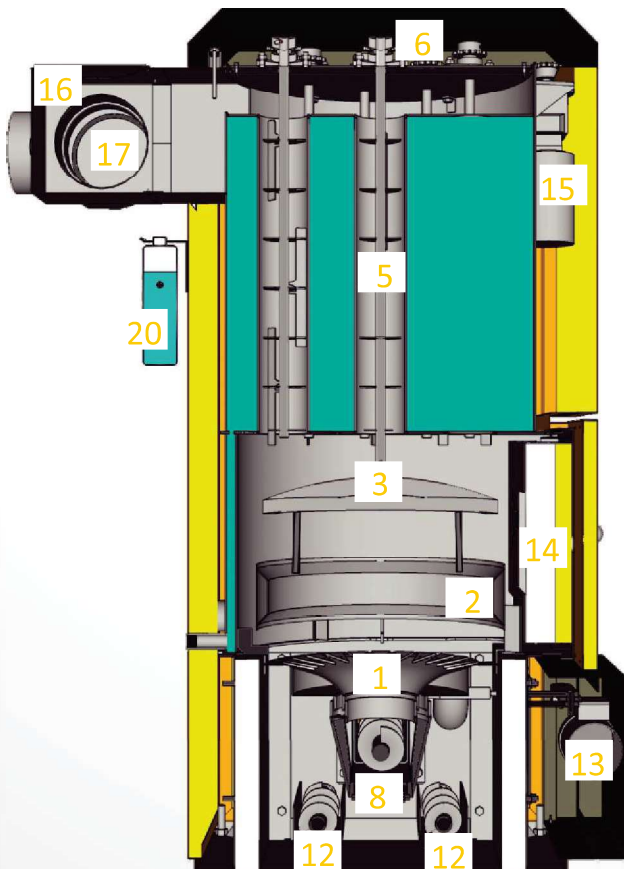

1. Primary burner with a moving grate
2. Secondary crown of additional combustion
3. Ceramic deflector
4. Ash container
5. Heat exchanger with turbulators
6. Turbulator drive
7. Control panel with touch screen
8. Feed screw
9. Disrupting mechanism
10. Intermediate fuel container
11. Separating flap of the intermediate container and fuel conveyor
12. Ash screws
13. Grating motor
14. Boiler service door
15. Turbulator drive motor
16. Chimney extension
17. Exhaust fan
18. Feed motor and ash screw motor
19. Accessories - Primary and secondary fan
  - Ignition fan
  - Emergency spark extinguishing device
21. Air duct cleaning
22. Double boiler insulation

# HAMONT 40-101 USV 1m<sup>3</sup>

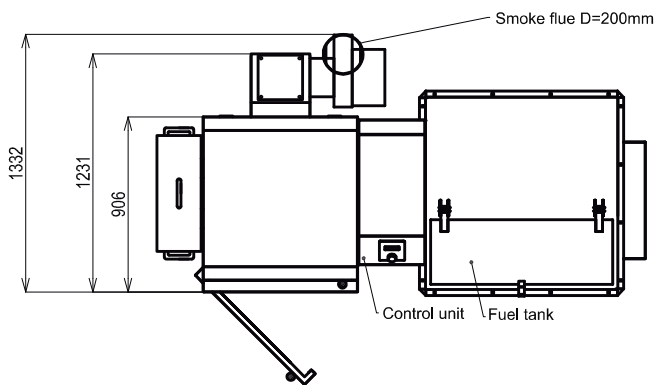
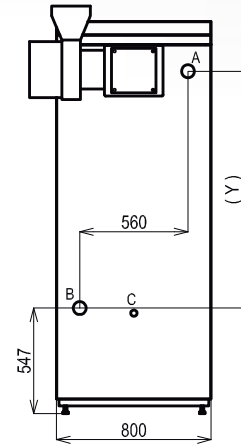
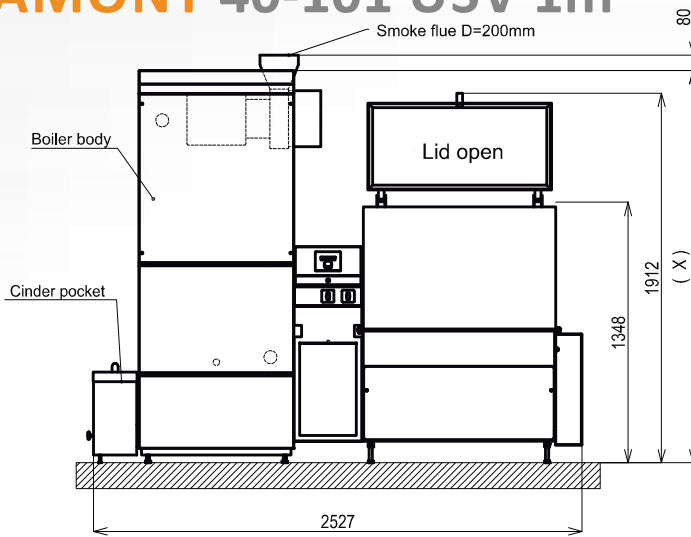

Type	HAMONT 40kW	49kW	60kW	80kW	99kW	100kW	101kW
High (X):	1830	1830	1830	2030	2030	2030	2030
Pitch (Y):	1025	1025	1025	1225	1225	1225	1225

# HAMONT 40-101 USZI

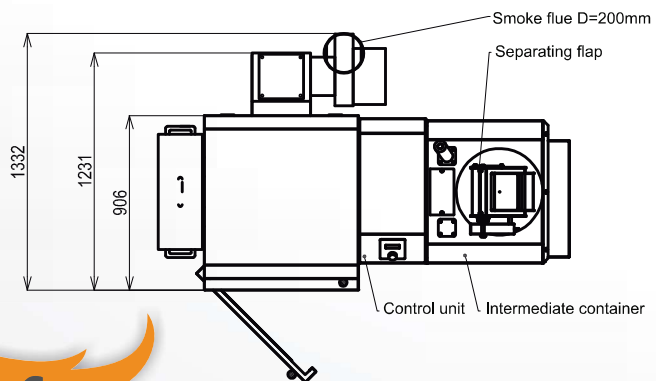
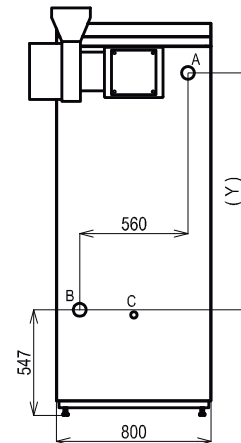
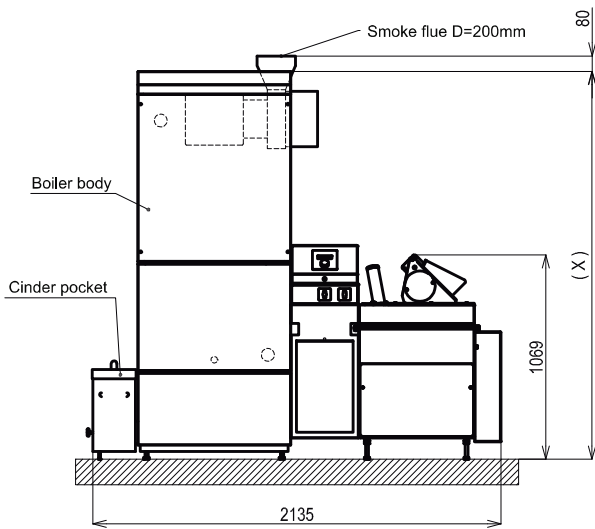

Type	HAMONT 40kW	49kW	60kW	80kW	99kW	100kW	101kW
High (X):	1830	1830	1830	2030	2030	2030	2030
Pitch (Y):	1025	1025	1025	1225	1225	1225	1225

A = Water - outlet G2"  
 B = Water - inlet G2"  
 C = discharge G3/4"

# HAMONT boiler technical data 40 – 101 US.. S2

Designation		40	49	60	80	99	100	101
Nominal power P <sub>n</sub>	kW	40	49	60	80	99	100	101
Partial load P <sub>min</sub>	kW	11	14	17	23	28	28	28
Boiler class / Fuel C1- wood pellets		5						
Ecodesign according to Commission Regulation (EU) No.2015/1189 for fuel C1		yes						
Boiler class / Fuel B1- wood chips		5						
Ecodesign according to Commission Regulation (EU) No.2015/1189 for fuel B1		yes						
Noise level	dB	<65						
Weight	kg	783	783	997	1042	1042	1042	1042
<b>Water</b>								
Volume of water	l	129	129	105	115	115	115	115
Water connection diameter	DN	50						
Hydraulic boiler loss at temperature gradient of 10°C	mbar	7,5	17	17	29,9	47	47	47
Hydraulic boiler loss at temperature gradient of 20°C	mbar	1,9	4,3	4,3	7,5	11,9	11,9	11,9
Boiler temperature	°C	60-90						
Min. temperature of return water	°C	55						
Max. temperature outlet water	°C	95						
Max. operating pressure	bar	3,5						
Test pressure	bar	5						
<b>Hearth temperature</b>	°C	<b>900-1100</b>						
Hearth pressure	mbar	-0,04						
Required chimney draught	mbar	0,15						
Need for artificial draught		yes						
Flue gas temperature at P <sub>n</sub>	°C	133	135	148	153	165	165	165
Flue gas temperature at P <sub>min</sub>	°C	91	88	94	93	96	96	96
Volume of flue gas at P <sub>n</sub>	kg/h	120	150	180	240	300	300	300
Volume of flue gas at P <sub>min</sub>	kg/h	39	50	60	81	99	99	99
<b>Chimney execution</b>		<b>Moisture-resistant</b>						
Smoke pipe diameter	mm	200						
Chimney diameter	mm	200						
<b>Fuel</b>								
Wood pellets EN ISO 17225-2		A <sub>1</sub> EN plus, A <sub>1</sub> , A <sub>2</sub> EN plus						
Wood chips EN ISO 17225-4		Moisture content M35, class A <sub>1</sub> , A <sub>2</sub> , B <sub>1</sub> a size P16S, P31S						
<b>Electric equipment</b>								
Connection		3PEN, 3X400/230V-50Hz, TNC-S/16A						
Total installed power	W	3048	3048	3131	3131	3131	3131	3131
Average operating power consumption	W	260	324	388	515	618	618	618

# Description of the **HAMONT** 150-500 kW boiler and functions

Power series: 150 kW – 180 kW – 199 kW – 220 kW – 250 kW  
300 kW – 350 kW – 400 kW – 450 kW – 499 kW – 500 kW

The boilers are predominantly supplied with moving equipment, which is moving from fuel warehouse to the boiler's intermediate container (USZI). Alternatively, the boiler may be installed with a 1-1.4 m<sup>3</sup> volume fuel container (USV). With account taken of the capacity of the boiler container, it is recommended for the present modification to further automate the supply of fuel (such as in combination with a silo). A screw conveyor is used to feed the fuel to the high-temperature combustion chamber, where it is ignited automatically. It burns out on a circular burner while primary air is fed in. The two-part secondary crown of additional combustion with secondary and tertiary air supply located above it provide for the full combustion of the emerging gases. Full combustion is supported by the deflector located above the combustion chamber, which at the same time adequately rectifies the direction of the flue gases prior to their entry into the heat exchanger. The same is located above the hearth, and its heat transfer surfaces are cleaned automatically. This guarantees

the high efficiency of the system. Optimal flow of flue gases is ensured by an exhaust with continuous control as a function of the actual under pressure in the combustion chamber, which is continually readout. For boilers falling into this power series, the exhaust fan is a part of the separator of solid pollutants (cyclone). Once burnt out, the ash is carried into the ash pocket using two feed screws. The function of the entire boiler is controlled by a control unit, which allows the setting of the required mode for each fuel used, and simultaneous two-way communication via a GSM modem. In the basic menu, the control unit enables visualization and remote access via the Internet on PC and mobile phone. The control unit optimises the combustion process across the entire range of power of the boiler by continually monitoring the oxygen surplus values by a lambda sensor in the flue gases. That guarantees the high efficiency of the facility across the entire range of controllability. Boiler power may be controlled within the range of 30 to 100%.

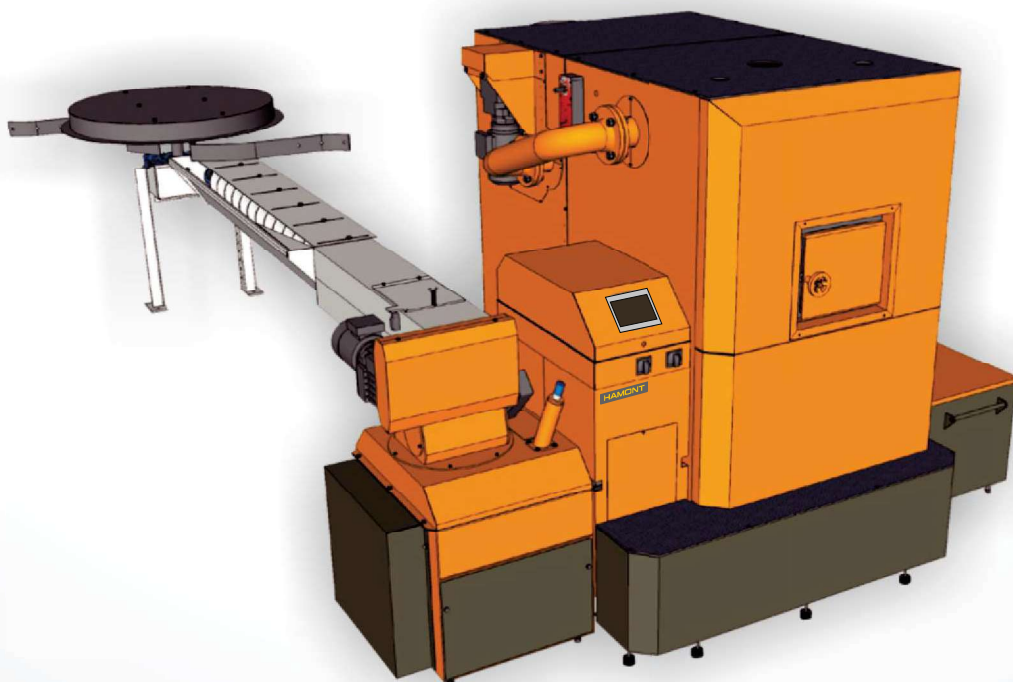



# Side cross-section

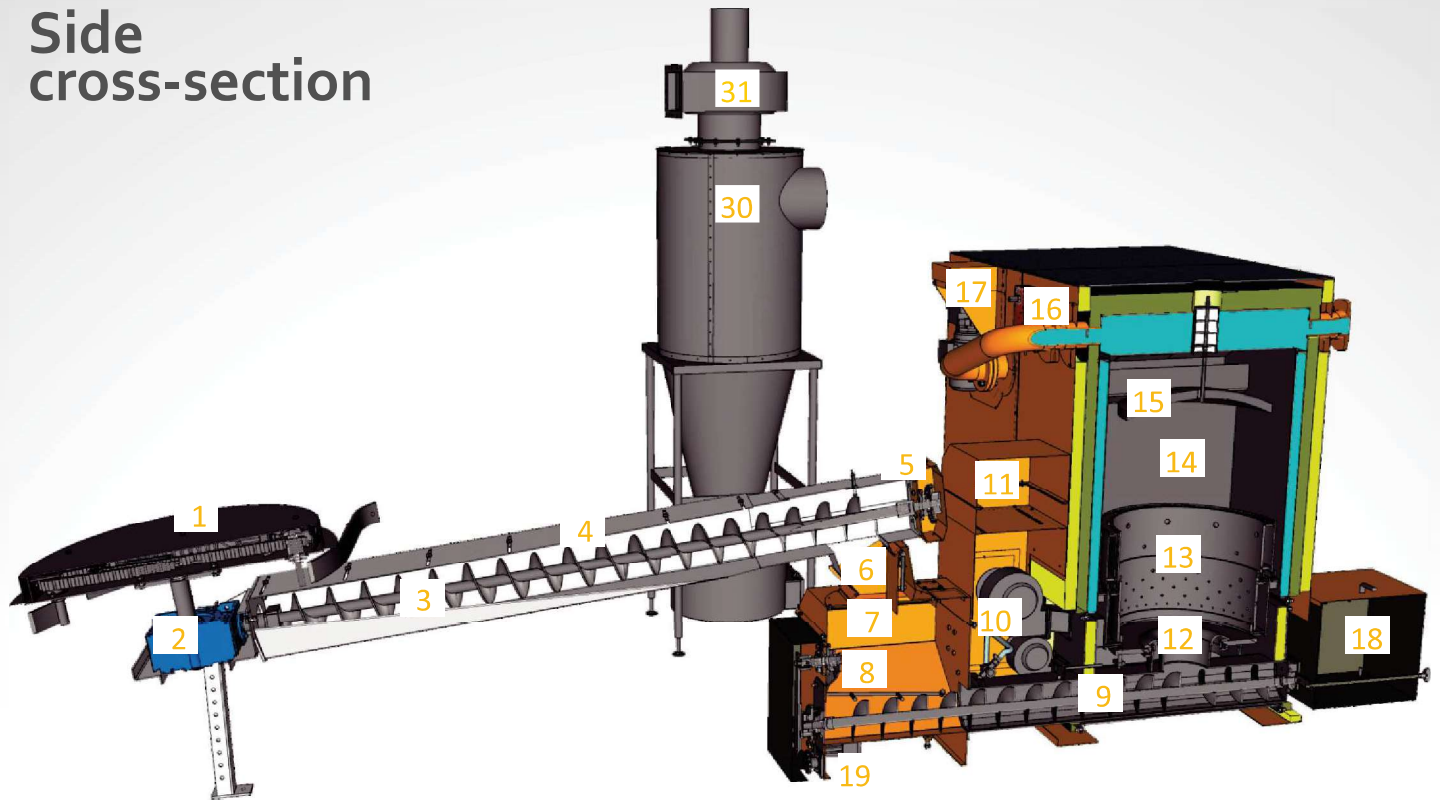

# Front cross-section

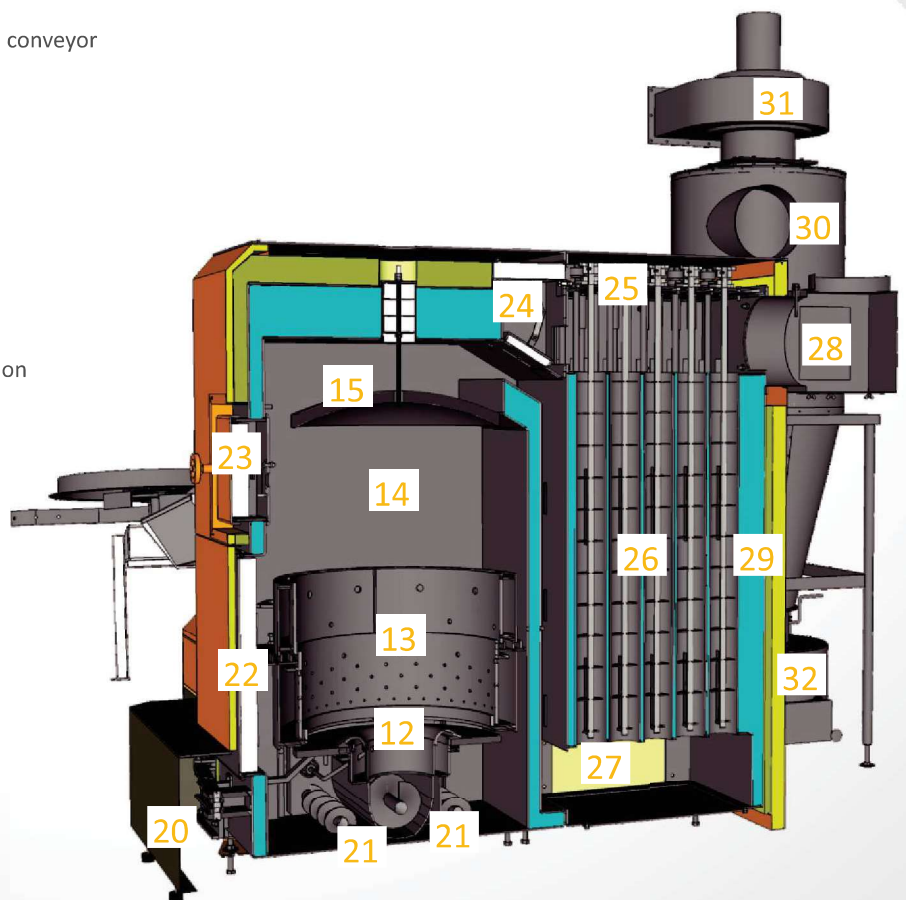

1. Spatial staging stirrer
2. Stirrer screw gear box
3. Conveyor screw
4. Fuel conveyor
5. Conveyor motor and gear box
6. Separating flap of the intermediate container and conveyor
7. Intermediate fuel container
8. Disrupting mechanism
9. Feed screw
10. Accessories - primary fan  
-secondary 1 fan  
-secondary 2 fan  
-igniting fan  
-emergency extinguishing facility
11. Control panel with touch screen
12. Primary burner with a moving grate
13. Two-way secondary crown of additional combustion
14. Combustion chamber
15. Ceramic deflector
16. Servo-drive of the flap of heat exchanger
17. Turbulator drive motor
18. Ash container
19. Feed screw motor
20. Grating mechanism with a motor
21. Ash screws
22. Boiler service door
23. Boiler inspection door
24. Exchanger flap
25. Turbulator drive
26. Heat exchanger with turbulators
27. Heat exchanger ash exhaust
28. Chimney extension
29. Double boiler insulation
30. Separator of solid pollutants
31. Exhaust fan
32. Separator ash container

# HAMONT 150 – 250 kW - USZI

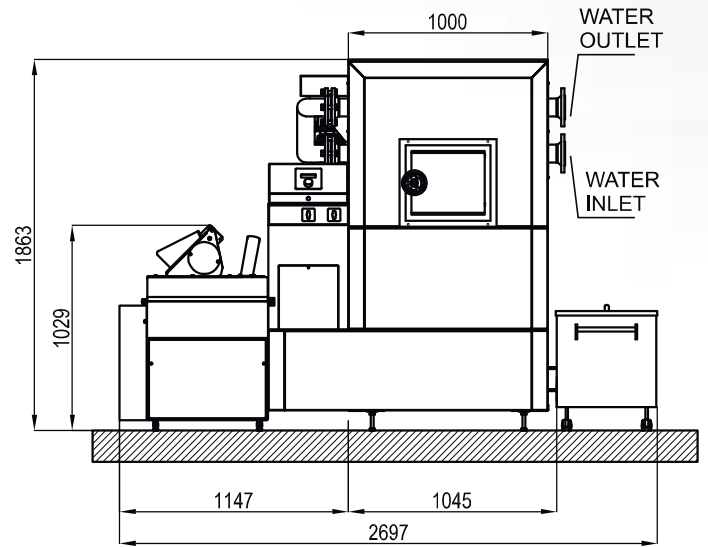
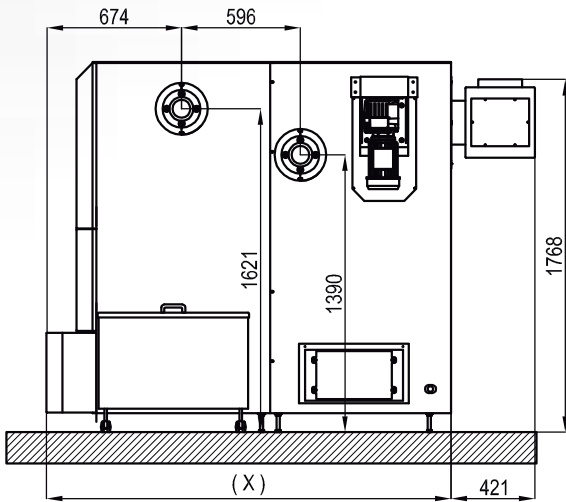

Type HAMONT	150kW	180kW	199kW	220kW	250kW
Length (X):	1668	1788	1908	1908	2028

# HAMONT 300 – 500 kW - USZI

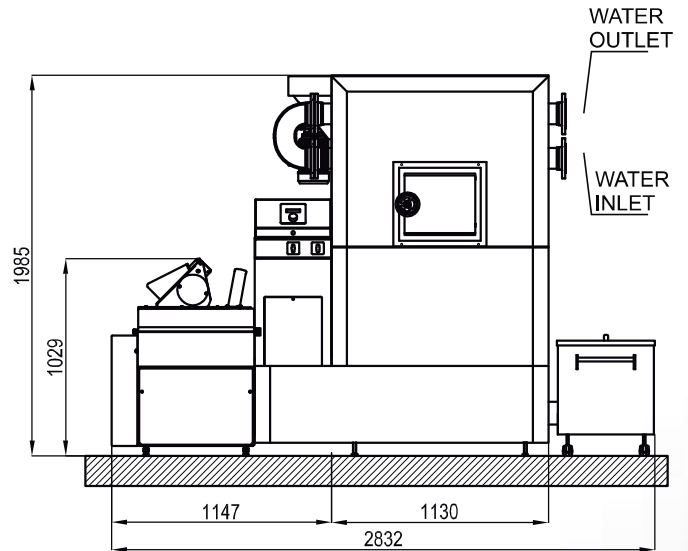
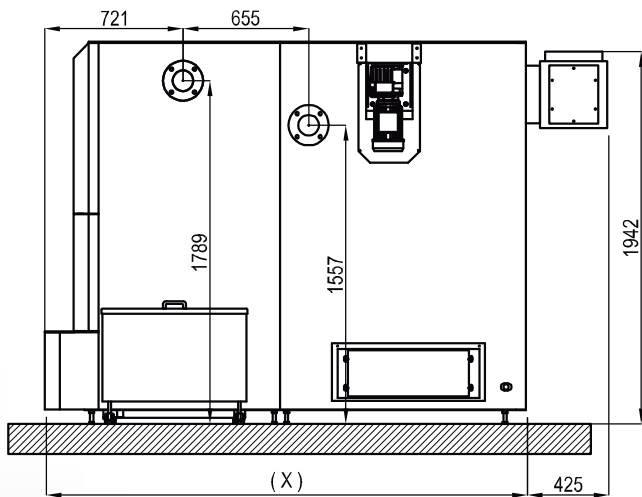

Type HAMONT	300kW	350kW	400kW	450kW	499kW	500kW
Length (X):	2028	2148	2268	2388	2508	2508

# HAMONT boiler technical data 150 - 500 US.. S2

Designation		150	180	199	220	250	300	350	400	450	499	500
Nominal power P <sub>n</sub>	kW	150	180	199	220	250	300	350	400	450	499	500
Partial Load P <sub>min</sub>	kW	40	45	50	55	65	75	90	100	115	140	140
Boiler class / Fuel C1-wood pellets		5										
Ecodesign according to Commission Regulation (EU) No.2015/1189 for fuel C1		yes										
Boiler class / Fuel B1 - wood chips		5										
Ecodesign according to Commission Regulation (EU) No.2015/1189 for fuel B1		yes										
Noise level	dB	< 65										
Weight	kg	2290	2370	2450	2450	2530	2750	2850	2950	3150	3250	3250
<b>Water</b>												
Volume of water	l	380	420	460	460	500	690	740	790	850	900	900
Water connection diameter	DN	80/PN6					100/PN6					
Hydraulic boiler loss at temperature gradient of 10°C	mbar	65	73	80	80	87	95	102	110	122	130	130
Hydraulic boiler loss at temperature gradient of 20°C	mbar	16	18	20	19	21	23	24	26	29	31	31
Boiler temperature	°C	60-90										
Min. temperature of return water	°C	55										
Max. temperature outlet water	°C	95										
Max. operating pressure	bar	3,5										
Test pressure	bar	5										
Hearth temperature	°C	900-1100										
Hearth pressure	mbar	-0,04										
Required chimney draught	mbar	0,15										
Need for artificial draught		yes										
Flue gas temperature at P <sub>n</sub>	°C	129	124	118	116	113	109	109	108	108	107	107
Draught after the boiler at P <sub>n</sub>	Pa	20										
Flue gas temperature at P <sub>min</sub>	°C	72	71	68	68	67	65	64	64	63	63	63
Draught after the boiler at P <sub>min</sub>	Pa	20										
Volume of flue gas at P <sub>n</sub>	kg/h	367	405	430	455	493	644	730	815	901	986	986
Volume of flue gas at P <sub>min</sub>	kg/h	140	152	160	168	180	238	243	247	252	256	256
Boiler operation		without condensation in the heat exchanger										
Chimney execution		resistant to moisture										
Smoke pipe diameter	mm	220					300					
Chimney diameter	mm	220					300					
<b>Fuel</b>												
Wood pellets EN ISO 17225-2		A1 EN plus, A1, A2 EN plus										
Wood chips EN ISO 17225-4		Moisture content M35, class A1, A2, B1 a size P16S, P31S										
<b>Electric equipment</b>												
Connect		3PEN, 3X400/230V-50Hz, TNC-S/16A										
Total installed power	W	4307	4307	4307	4307	4307	5719	6269	6269	6269	6269	6269
Average operating power consumption	W	266	300	334	369	403	693	713	733	752	772	772

# Control unit

Boiler operation is controlled automatically by the control unit CSTREG according to preset program.

- Communication protocol Modus RTU, Modus RTU/IP or just status signal.
- Sending failure signals and communication via GSM gate.
- Touch screen and remote Internet management in the basic menu
- Ability to control buffer tank, two equithermic heating branches and DHW heating in base.
- Select operating language (CZ, SK, EN, ES, FR, PL)

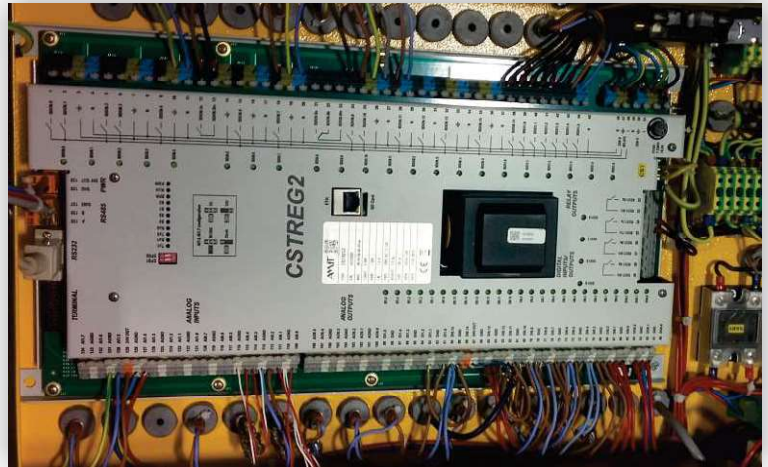

Control unit CSTREG situated in boiler switchboard



Main switch and control panel

# Control elements

The basic control element of the boiler is the main switch situated on the front panel of the boiler, which interrupts the power supply to the switchboard and thus the whole boiler. Along with it is located on the panel reverse switch, which can change the direction of rotation of three-phase drives for a short time. The industrial terminal with 7 "colour touch screen is used for setting the boiler operation parameters and its control. Operation is carried out by means of touch buttons. Control and setting buttons are accessed via passwords according to the user's level of competence. There is a three-level security to prevent incorrect boiler operation. The terminal allows you to set a weekly schedule of boiler operation for individual days of the week or their summaries.

# Visualization of boiler operation

It is a possibility of remote supervision and changes of some parameters of HAMONT device. This simple visualization makes it possible to check the inlet and outlet temperatures of the heating medium, the temperature of the regulated heating circuits, the temperature of the flue gases and the operating status of the boiler. It also enables remote setting of the required output temperature of the boiler heating medium, stoking rhythm, parameters of heating circuits or devices remotely switched on or off.

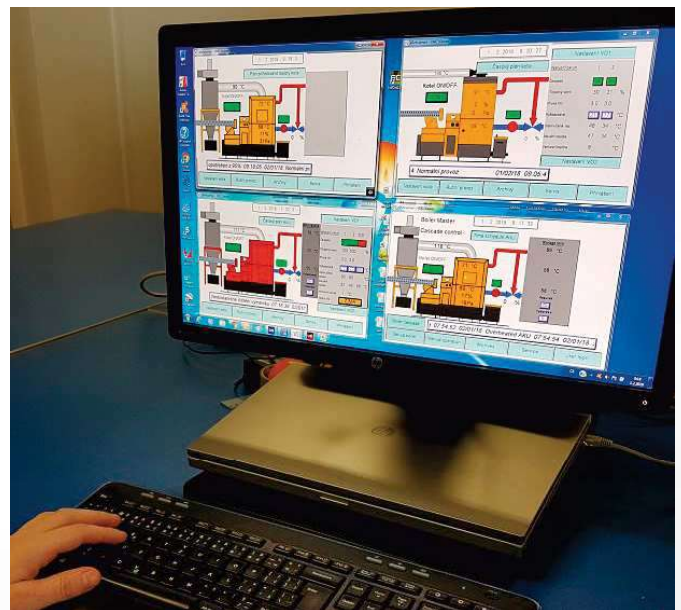

Visualization on PC

Monitoring of boiler operation and operation can also be done via smathphone or tablet in a simple, fast and user-friendly way. Operation is the same as on the touch screen on the boiler. This way it is possible to monitor and change its parameters anytime and anywhere. Easy-to-navigate menu navigation and easy-to-use screen layout for maximum operator comfort.

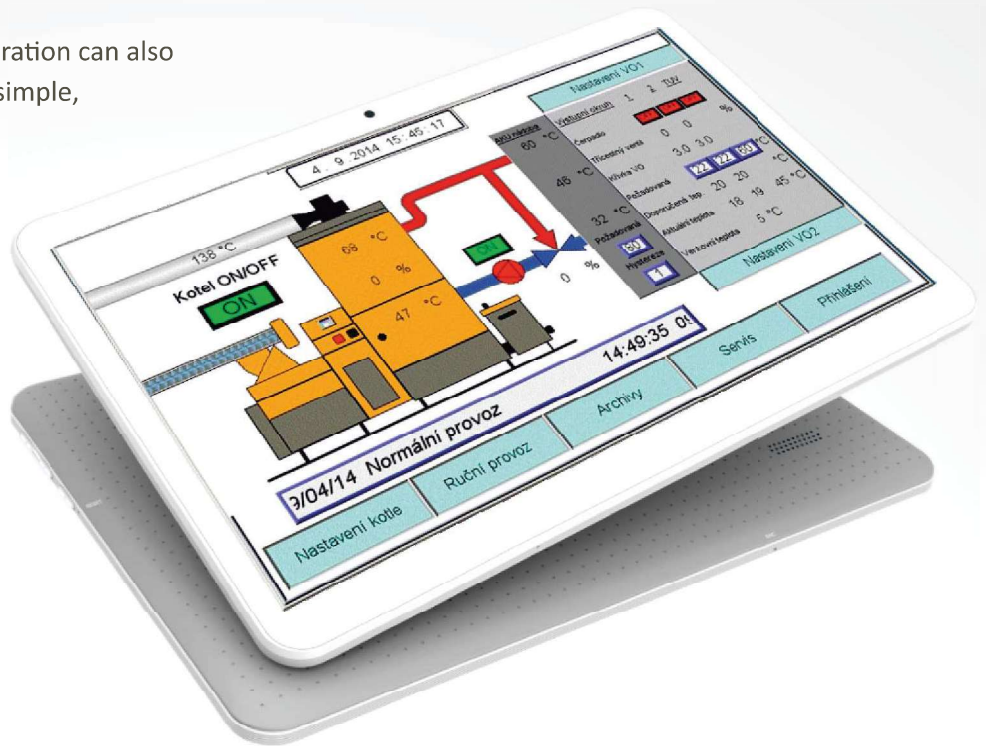

## Safety and economy of operation

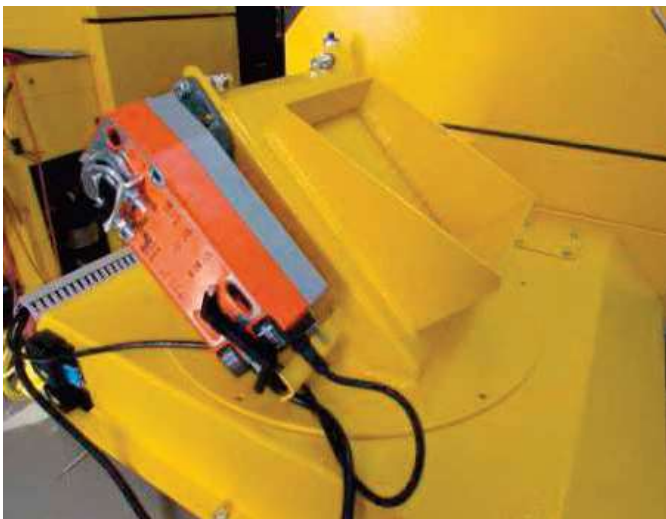

1. The boiler fuel feeder conveyor and the intermediate fuel container are made absolutely tight. Position motor opens and closes the flap transportation of fuel begins when fully open flap. When is a failure or power outage, the flap closes over the spring automatically. When we carry out maintenance, flap must be closed except work with directly related.

2. The emergency spark extinguishing device, which is part of the feed screw, it is consist of safety thermostatic valve. (The thermostatic valve has maximum temperature for opening 95°C). And barrel of water with sensor of water level. The capillary inside a thermostatic valve is welded on

the both sides with the feed screw. In the barrel of water is drain valve, which must be in open position. In the case that the emergency spark is active. A fuel which is the feed screw is flushed by water. Sensor of water level turns off the boiler automatically.

3. The device is protected by safety and irreversible thermostat. When exceeding the boiler temperature above 110 °C, the device is shutting down.

4. Lambda sensor – optimalization process of combustion in terms of emissions.

5. Heat exchanger design optimized to achieve high efficiency with automatic cleaning heat exchange surfaces.



# Types of fuels used



**Crushed wood – e.g. as recycled**

30x30 mm (40x40) fraction –moisture content up to 35%



**Wood chips**

30x30 mm (40x40) fraction –moisture content up to 35%



**Wooden briquettes**

80 mm dia – 50 mm length



**Mix chipboard waste + wood chips**

Sawdust, granulate, pressed briquettes (boilers over 300 kW)



**Fine shavings**

Moisture content up to 35%



**Wooden pellets**

6 mm and 8 mm dia

# Images of fuel depots

**Chips**



**Pellets**



# Theoretical (calculated) consumption of fuel of **HAMONT** boilers

The practical consumption for the entire heating season 210 days, approximately 60% of the stated values

consumption for the time period t	Type of boiler	Type of fuel					
		pellets (18MJ/kg) (650 kg/prms)		Fine shavings (12,5MJ/kg) (150 kg/prms)		Wood chips (12,5MJ/kg) (230 kg/prms)	
		kg	prms	kg	prms	kg	prms
Day	Hamont 40 kW	212,86	0,33	306,52	2,04	306,52	1,33
Year	Hamont 40 kW	44 701	69	64 369	429	64 369	280
Day	Hamont 49 kW	266,43	0,41	383,66	2,56	383,66	1,67
Year	Hamont 49 kW	55 951	86	80 569	537	80 569	351
Day	Hamont 60 kW	320,00	0,49	460,80	3,07	460,80	2,00
Year	Hamont 60 kW	67 200	103	96 768	645	96 768	421
Day	Hamont 80 kW	429,53	0,66	618,52	4,12	618,52	2,69
Year	Hamont 80 kW	90 201	139	129 890	866	129 890	565
Day	Hamont 99 kW	544,22	0,84	783,67	5,22	783,67	3,41
Year	Hamont 99 kW	114 286	176	164 571	1 097	164 571	716
Day	Hamont 100 kW	544,22	0,84	783,67	5,22	783,67	3,41
Year	Hamont 100 kW	114 286	176	164 571	1 097	164 571	716
Day	Hamont 101 kW	544,22	0,84	783,67	5,22	783,67	3,41
Year	Hamont 101 kW	114 286	176	164 571	1 097	164 571	716
Day	Hamont 150 kW	760,30	1,17	1 094,83	7,30	1 094,83	4,76
Year	Hamont 150 kW	159 662	246	229 913	1 533	229 913	1 000
Day	Hamont 180 kW	910,43	1,40	1 311,02	8,74	1 311,02	5,70
Year	Hamont 180 kW	191 191	294	275 315	1 835	275 315	1 197
Day	Hamont 199 kW	1 010,42	1,56	1 455,01	9,70	1 455,01	6,33
Year	Hamont 199 kW	21 503	327	305 552	2 037	305 552	1 329
Day	Hamont 220 kW	1 110,41	1,71	1 598,99	10,66	1 598,99	6,95
Year	Hamont 220 kW	233 186	359	335 788	2 239	335 788	1 460
Day	Hamont 250 kW	1 259,18	1,94	1 813,22	12,09	1 813,22	7,88
Year	Hamont 250 kW	264 428	407	380 776	2 539	380 776	1 656
Day	Hamont 300 kW	1 536,82	2,36	2 213,02	14,75	2 213,02	9,62
Year	Hamont 300 kW	322 732	497	464 734	3 098	464 734	2 021
Day	Hamont 350 kW	1 783,44	2,74	2 568,15	17,12	2 568,15	11,17
Year	Hamont 350 kW	374 522	576	539 312	3 595	539 312	2 345
Day	Hamont 400 kW	2 027,46	3,12	2 909,54	19,46	2 919,54	12,69
Year	Hamont 400 kW	425 766	655	613 102	4 087	613 102	2 666
Day	Hamont 450 kW	2 271,29	3,49	3 270,66	21,80	3 270,66	14,22
Year	Hamont 450 kW	476 972	734	686 839	4 579	686 839	2 986
Day	Hamont 499 kW	2 510,46	3,86	3 615,06	24,10	3 615,06	15,72
Year	Hamont 499 kW	527 197	811	759 163	5 061	759 163	3 301
Day	Hamont 500 kW	2 510,46	3,86	3 615,06	24,10	3 615,06	15,72
Year	Hamont 500 kW	527 197	811	759 163	5 061	759 163	3 301

Fuel consumption depends on the method of heating, heat losses, and the quality of the fuel moisture content and the state of the heating system.

# Conveyor systems

## Screw conveyor with a spring rake mechanism **HAMONT**

If we want to achieve greater operator comfort (both lower power boilers and higher power boilers), we select the conveyor system at the fuel warehouse by type of fuel used. Transport of fuels from warehouses, regardless of whether they are specially designed silos or rooms in existing buildings specially modified for those purposes, is provided for by a spatial staging system. The premises of the warehouse may have a circular, square, or rectangular (4:3) ground plan, and the flow may be next to, over or below the level of the boiler room floor. The staging system therefore can also be adapted with regard to the various layouts of the warehouse thanks to the fact that the conveyor may be oriented vis-à-vis the intermediate container near the boiler within the range of 230° in the horizontal and 25° in the vertical plane. The length of the conveyor may then be up to 12 metres. Our spatial staging system is equipped with a screw conveyor with a dual screw shaft support, which displays a progressive rising gradient that prevents clogging. The transport of fuel from the warehouse begins the moment

the ultrasonic sensor in the intermediate container assesses the amount of fuel as being insufficient. The time required for the top-up of the optimum quantity of fuel changes depending on the energy content and apparent density of fuel. The servo-driven separating flap in the mouth of the conveyor ensures protection against reverse burning, complemented by emergency extinguishers. The flap is open for such period of time only as required for the fuel to be topped up, and then it hermetically separates the intermediate container from the fuel warehouse. Optimum emptying of the fuel warehouse, even for large diameters of the spatial stirrer, is ensured by means of the uniform pressure of arms across its entire diameter range. The average leaf spring beam modification in connection with massive steel arms: 5,5 m. The high reliability, life and wear resistance are given by the structural solution, materials used, and components. This system is suitable for the case of heating different fuels (wood chips, pellets, crushed wood, soft briquettes, ...) according to the availability of fuel, this system is universal.

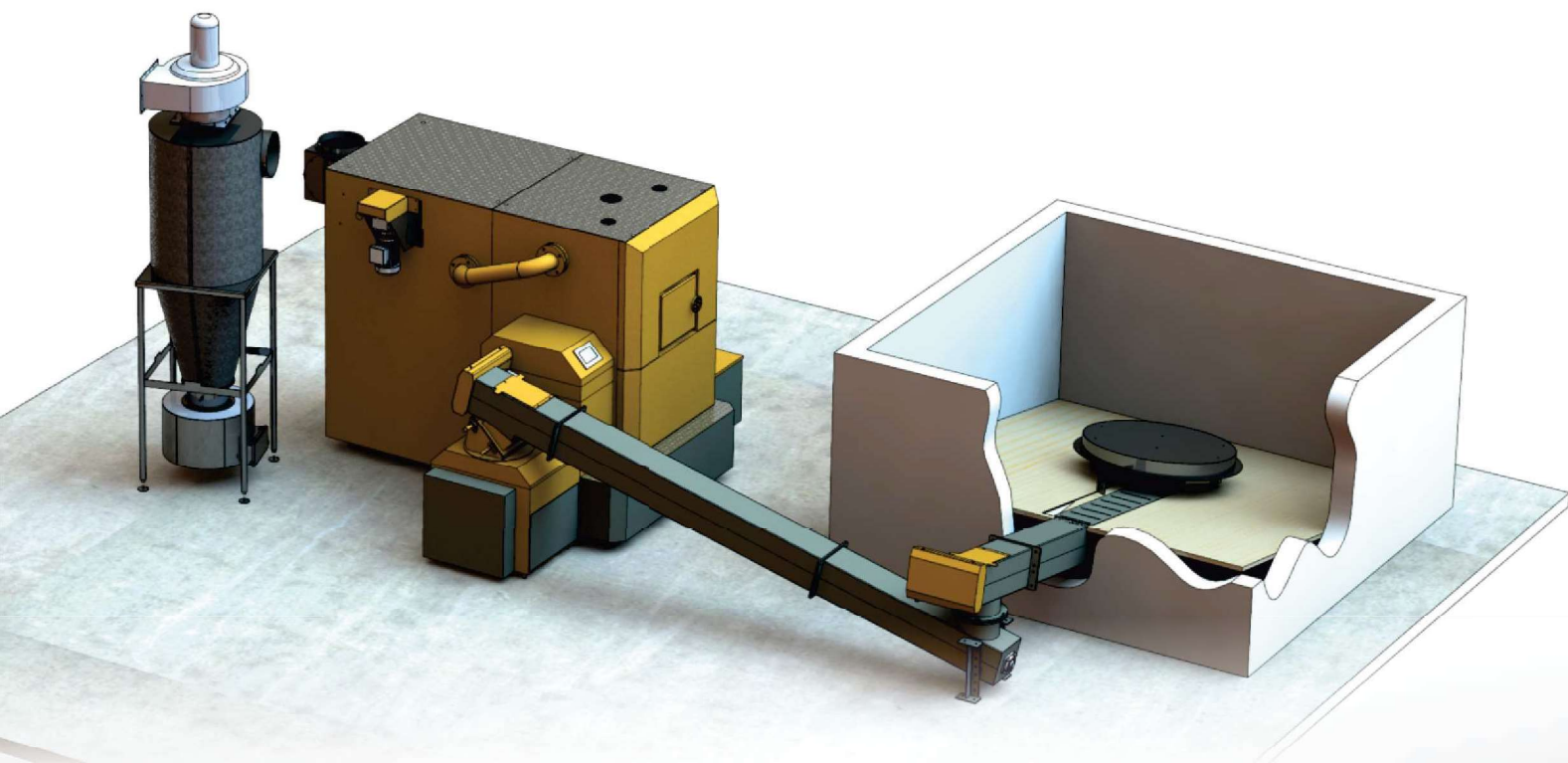



## Associated conveyors

The best transportation of fuel for boilers connected in cascade is to choose a common conveyor system. This is common for both boilers stirrer and a separate screw conveyors to individual boilers.

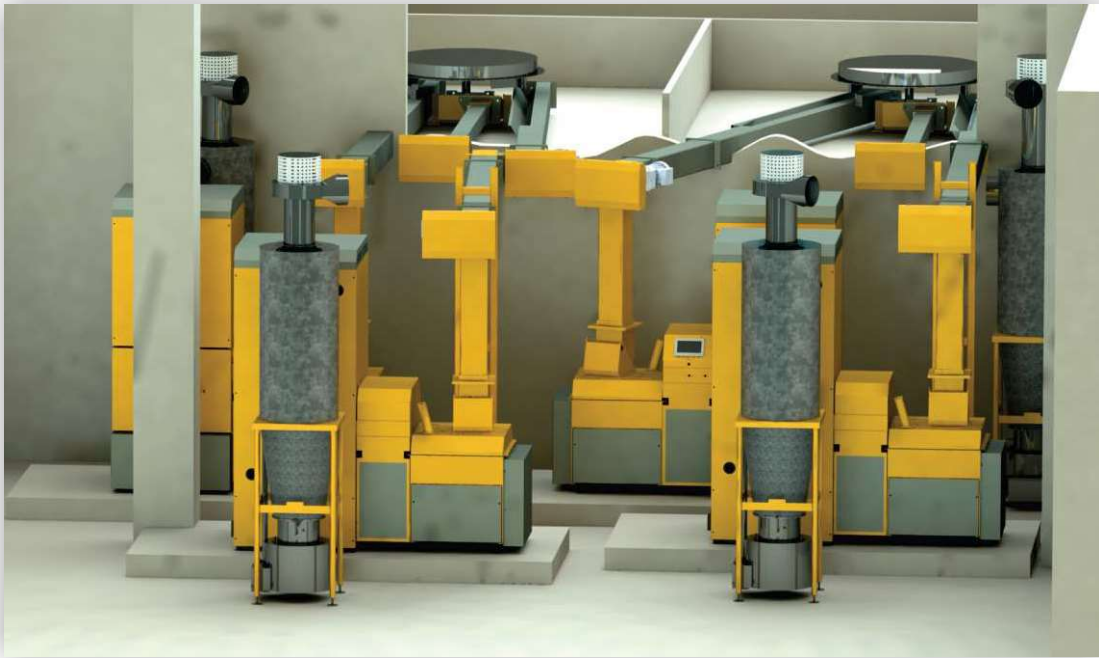

## The screw pellet conveyor **HAMONT**

If the boiler will burn only wood pellets, we offer a variant of the warehouse in a V-shaped, at an angle about 45°. There is a possibility of complete emptying of warehouse and also the possibility of fulfilling blowing pellets from storage tank to storage. Maximum length of warehouse is 6,5 m. The disadvantage is unused warehouse space under descent boards.

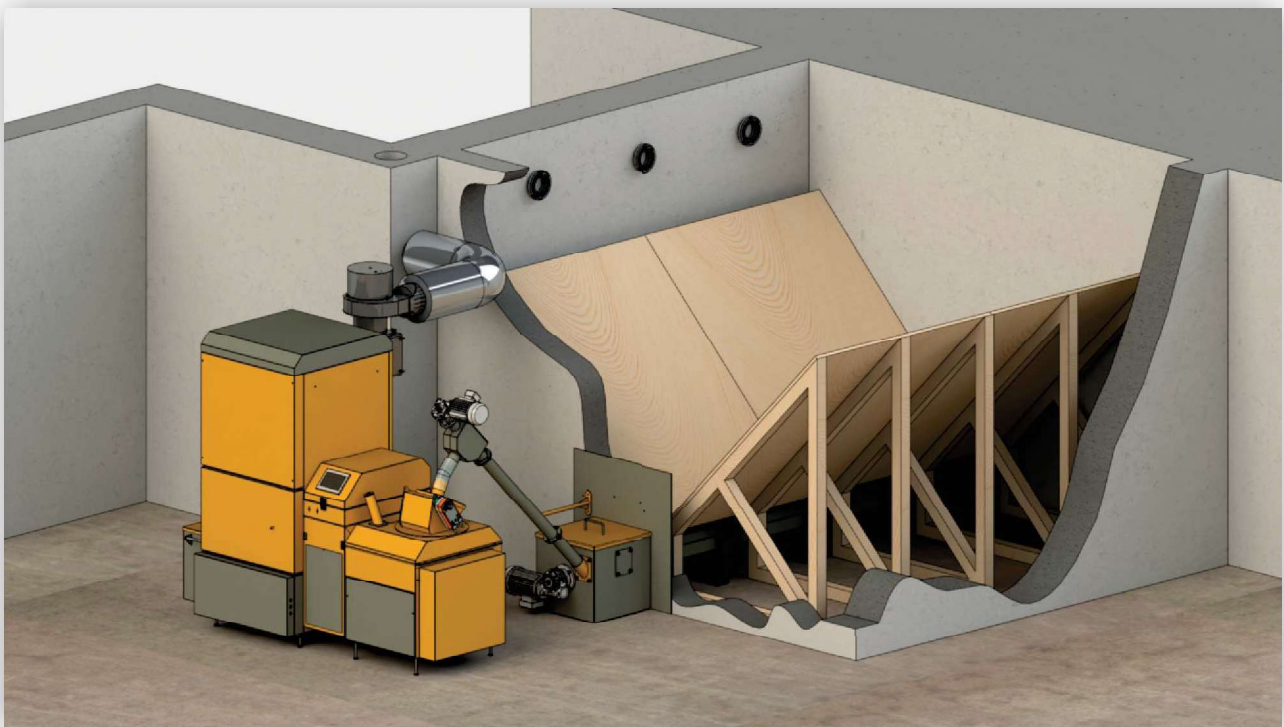

## Example of hydraulic connection of 40 – 101 kW boiler **HAMONT**

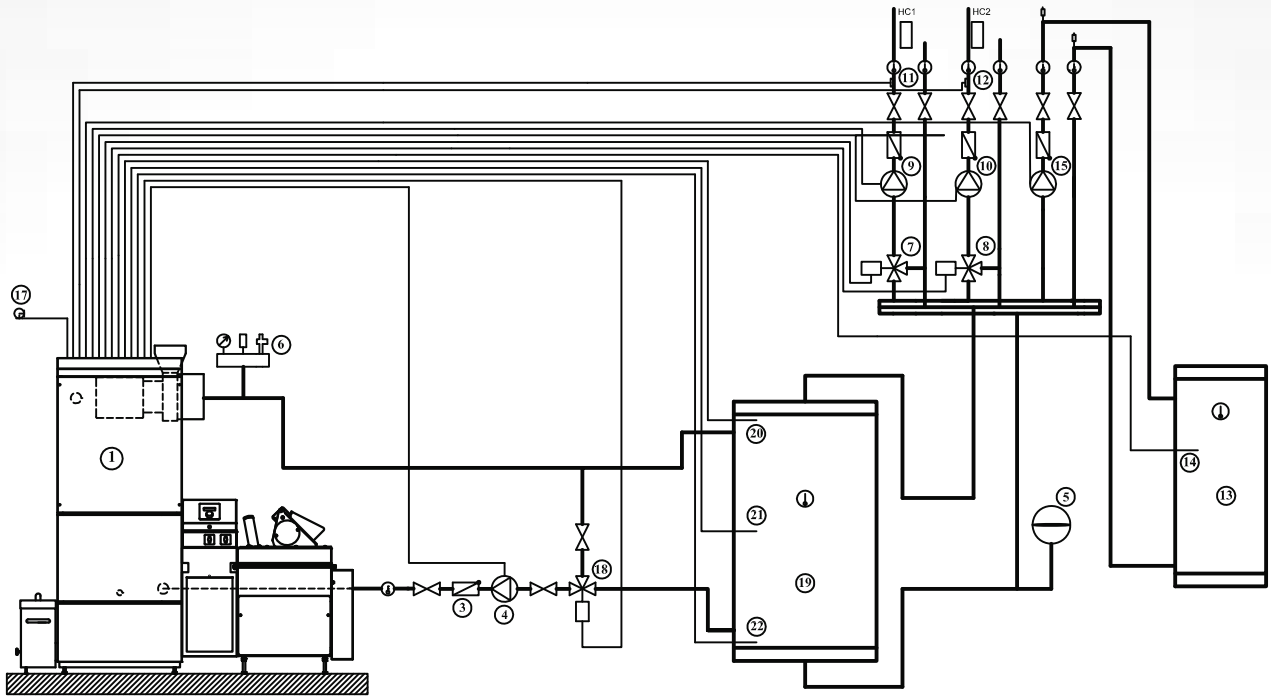

## Example of hydraulic connection of 150 – 500 kW boiler **HAMONT**

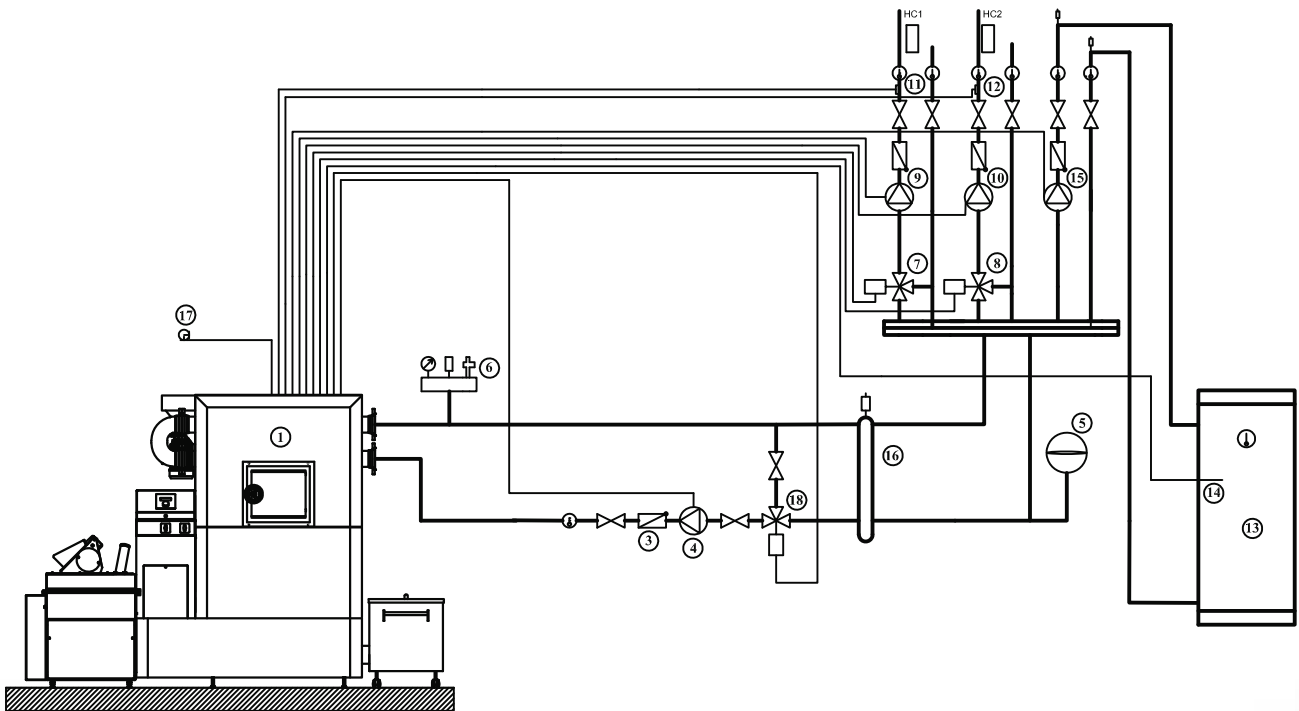

- |   |                                  |
|---|----------------------------------|
| 1. Boiler                                     | 9. Pump HC1                      |
| 3. Reverse flap                               | 10. Pump HC2                     |
| 4. Circulating pump                           | 11. Temperature sensor HC1       |
| 5. Pressure expansion vessel                  | 12. Temperature sensor HC2       |
| 6. Overpressure valve, manometer, bleed valve | 13. Boiler                       |
| 7. 3-way valve HC1                            | 14. Boiler temperature sensor    |
| 8. 3-way valve HC2                            | 15. Boiler pump                  |
|   | 16. Hydraulic pressure equaliser |
|   | 17. Outdoor sensor               |
|   | 18. 3-way shorting valve         |

# Reference installations



Object: **Jelínek- Furniture production, s.r.o.**  
City: **Valašské Meziříčí (CZ)**  
Boiler type: **2 x HAMONT 500 kW USZI**  
Fuel: **Waste from production**  
Year of realization: **2000/2010**



Object: **Block of flats + Brewery**  
City: **Karpentná (CZ)**  
Boiler type: **HAMONT 500 kW USZI**  
Fuel: **Wood chips**  
Year of realization: **2006**



Object: **Container boiler house**  
City: **Visby - Gotland ( Sweden )**  
Boiler type: **HAMONT 250 kW USZI**  
Fuel: **Wood chips**  
Year of realization: **2010**



Object: **SOŠ Frýdek-Místek**  
City: **Frýdek-Místek (CZ)**  
Boiler type: **4x HAMONT 100 kW USZI**  
Fuel: **Pellets**  
Year of realization: **2011**



Object: **Ador CZ s.r.o.**  
City: **Dolní Dobrouč (CZ)**  
Boiler type: **HAMONT 400 kW USZI**  
Fuel: **Soft briquettes**  
Year of realization: **2012**



Object: **ZŠ Oravská Lesná**  
City: **Oravská Lesná (SK)**  
Boiler type: **HAMONT 400 kW USZI**  
**HAMONT 150 kW USZI**  
Fuel: **Pellets**  
Year of realization: **2013**



Object: **Cestmajsterstvo Ilava**  
City: **Ilava (SK)**  
Boiler type: **HAMONT 60 kW USZI**  
Fuel: **Wood chips**  
Year of realization: **2014**





Object: **ZŠ Kvasice**  
City: **Kvasice, dist. Kroměříž ( CZ )**  
Boiler type: **2 x HAMONT 199 kW USZI**  
Fuel: **Pellets**  
Year of realization: **2015**



Object: **Jack Tighe Ltd.**  
City: **Scunthorpe, Park Farm Rd ( GB )**  
Boiler type: **8 x HAMONT 499 kW**  
Fuel: **Pellets**  
Year of realization: **2016**



Object: **Dřevotvar cooperative**  
City: **Jamné nad Orlicí ( CZ )**  
Boiler type: **HAMONT 400 kW USZI**  
Fuel: **Wood chips**  
Year of realization: **2017**



Object : **SCZT Solenice**  
City : **Solenice, dist. Příbram ( CZ )**  
Boiler type : **HAMONT 300 kW USZI**  
**HAMONT 100 kW USZI**  
Fuel : **Pellets**  
Year of realization: **2018**



Object : **Blocks of flats Huzová**  
City : **Huzová, dist. Olomouc ( CZ )**  
Boiler type : **2x HAMONT 101 kW USZI**  
Fuel : **Pellets**  
Year of realization: **2019**



# CSTfire

CSTfire s.r.o.  
Výstavní 2937/132a  
703 00 Ostrava-Vítkovice  
Czech Republic

Tel.: +420 702 252 492  
+420 596 753 009  
info@cstfire.com  
www.cstfire.com

